

P-CHARGE EWS-Box

Controller for the electric charging stations

1.1 Preface

The EWS Box communication module undertakes all control- and notification functions necessary, according to IEC 61851 Mode 3, for the connection of an electric vehicle (EV) to a cable-linked supply unit. Parameters for a self-sufficient or for a systems-integrated operation can be configured via HTML pages.

2.1 Technical data

Nominal voltage / Frequency	230V/50Hz
Input power	3.5W (max.)
Locking actuator	2x12V/3A
Electrical switching power	AC-15 2x 300VA
Ambient temperature (operation)	-20 bis 70°C
Relative air humidity	< 93%
Overvoltage category	II
Protection class	IP20
Housing	6TE DIN-Support rail 35mm

3.1 Terminal clamps and connections

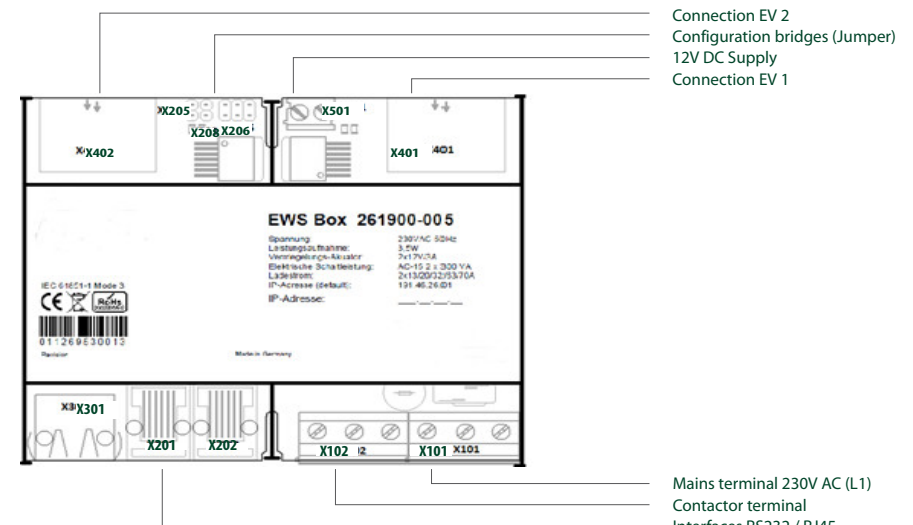

SETTINGS: Under Settings, details such as date, time and user data can be generated. In RFID card administration, card ID's and group ID's can be generated. Each card can then be programmed and configured in conjunction with its respective RFID card reader. The blocking of invalid cards is also possible here. Several EWS Boxes can be administered on the network by entering user data and the corresponding server settings on the customer-side.

Detailed specifications can be found in the operating instructions

INSTALLATION: Required settings relating to plug and cable systems from the respective manufacturers can be entered here. A meter can be used across an SO interface for determining the kWh output. Once Impulse/kWh have been set, these can then be evaluated via the EWS Box. Similarly, maximum charge, previously defined via the jumper, can be further limited according to customer requirements.

Detailed specifications can be found in the operating instructions

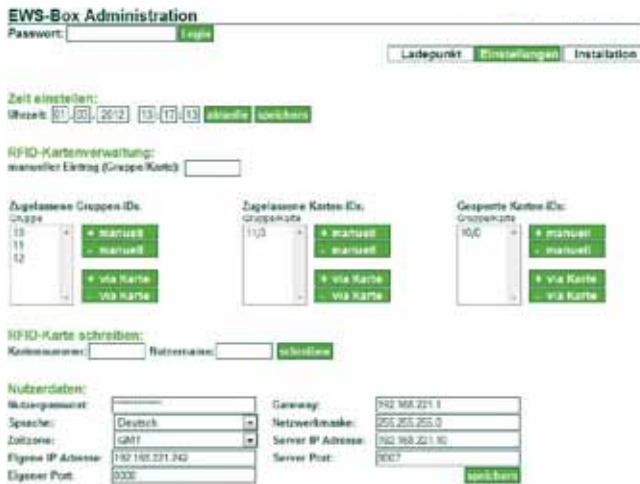

NOTE: Installation, commissioning and maintenance operations should be performed exclusively by expert personnel. Initiating charging processes with a gassing battery and inadequate ventilation can lead to a build-up of hydrogen gas. In such cases there is a risk of explosion!

DISCLAIMER: We accept no liability for inadvertent omissions or divergences of content in printed material. This information will be evaluated at regular intervals and any necessary modifications added to subsequent editions.

DOWNLOADS: (Operating instructions/the Quick Guide to Operations/Firmware) under: www.SSL-Energie.de

3.1.1 Mains terminals and contactor terminals

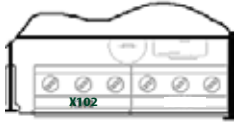

Grounding conductor (PE)
Neutral conductor (N)
Phase (L1)
Contactor EV 1
Contactor EV 2
Contactor fan

Cross sections: 0.2-2.5mm²/Tightening torque: 0.5-0.6Nm
MAINS TERMINALS Connection to the grid is effected across the mains terminal (L1/N/PE) for the EWS Box, for the contactor circuits and for the ventilation circuitry.

CONTACTOR TERMINALS The wiring of contactor coils is effected via the EWS Box. Care is to be taken that for each EV, a nominal charge of max. 300VA (AC-15) can be activated. The fan connection activates a contactor / relay which serves both electric vehicles in equal measure.

NOTE: These connections are designed solely for the activation of charging contactors and/or fan contactors and should never be used for the transmission of power to an EV!

3.1.2 Connections EV 1 and EV 2

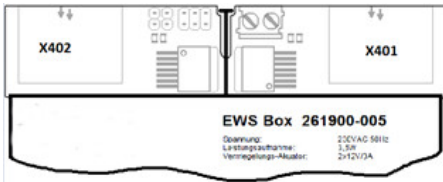

Cross sections: 0.14 - 0.5mm²
The EWS Box has the capacity to provide an independent supply of power to 2 electric vehicles (EV) simultaneously. EV 1 is connected to X401 and EV 2 to X402. The two connections are identical. The connection plan is therefore presented for just one socket assembly.

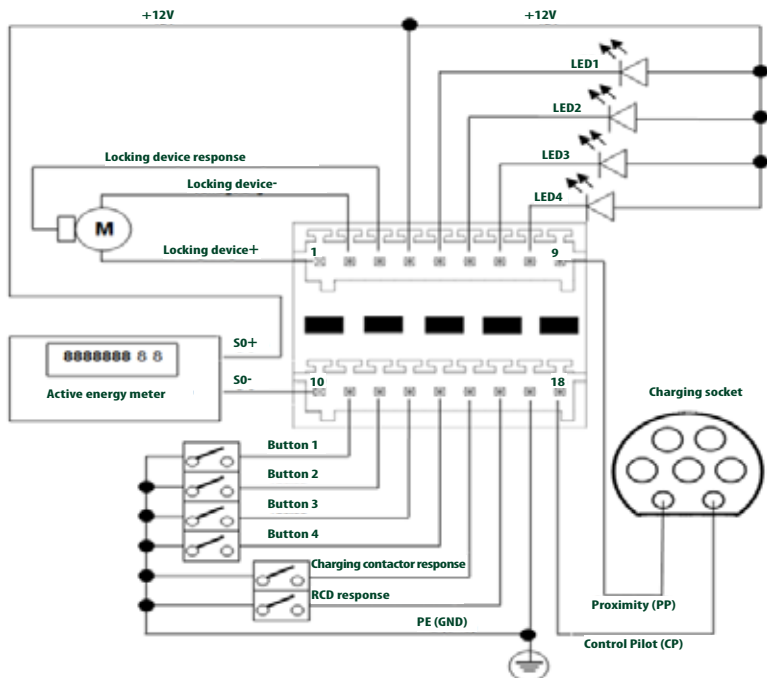

3.1.3 12V DC Supply

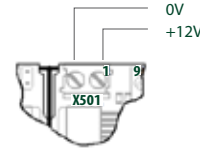

Cross sections: 0.25-2.5mm²/Tightening torque: 0.5-0.6Nm
The feed from an external 12V DC power supply is effected across X501. The energy required for the integrated locking mechanisms is also provided. The 12V DC now available can provide the module with an emergency supply of power for a period of time. The EWS Box acknowledges a power outage and triggers an emergency release.

NOTE: This function is not designed to provide a continual supply of power to the module during a power outage. It serves solely to terminate a charging session safely and to secure any data. The power supply must be capable of operating at full capacity for a period (Hold up Time) of min. 200mins per connected user! This is no longer mandatory if the P-Version (POWER BACKUP) is used which incorporates this functionality.

3.1.4 Interfaces

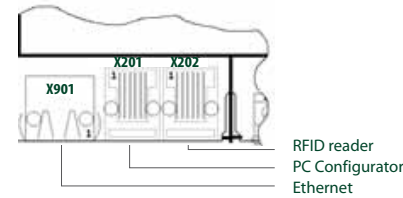

RFID READER The RFID card reader connection enables the control and monitoring of authorized access to the system.

PC CONFIGURATION: This connection allows for the entry of system-relevant settings and for the transmission of permanent status queries.

ETHERNET: The internet connection supports data transfer as per 10/100BASE-T and is allocated a MAC Address prior to transmission. The IP address is preset (192.168.0.1) and can be changed via the configuration settings (no DHCP).

4.1 Configuration

4.1.1 Configuration via configuration switch (Jumper)

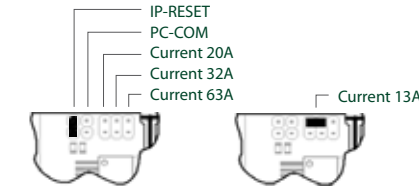

CHARGING POWER A specific output capacity can be allocated to the EWS Box. This can be effected using the jumper, which needs to be connected at start-up of the module in order for the hardware to be recognized.

IP-RESET On removal of the jumper during operation, the current IP address automatically resets to the default configuration: 192.168.0.1.

PC-COM Connection of the jumper forces local administration across the PC interface X201. Software updates can be implemented on the EWS Box using this procedure.

4.1.2 Configuration via EWS-Box Administration (HTML)



CHARGING POINT: Once the default IP address has been added, the Start Page is displayed. The respective operation of both charging points is displayed. At factory setting no password is required for login. A password can be generated under the Menu Item Installation.